

Conflict and Negotiation in International Riparian Disputes*

J. Joseph Hewitt
University of Missouri-Columbia

Anja Kurki
University of Maryland

Joe A. Oppenheimer
University of Maryland

* An earlier version of this paper was presented at the 1998 Annual Meeting of the International Studies Association, Minneapolis, Minnesota.

Abstract

This study presents a game theoretic model of interactions between neighboring states that share water resources from a river flowing through the territory of both states. A conflict exists between the two states because the upstream riparian prefers to construct a diversion project of some kind that will reduce the downstream state's access to water resources. In order to facilitate analysis, the study provides a delineation of various classifications of upstream and downstream riparians in terms of their preferences for possible outcomes. The model provides a theoretical clarification for how increasing water scarcity can increase the likelihood of escalated international conflict. Negotiated settlements are most likely when the upstream state believes the downstream state is likely to be strongly resolved to block any effort to build an upstream dam. Escalated conflicts are especially likely when the upstream state proceeds with plans for dam construction under the mistaken belief that the downstream state is unlikely to oppose those efforts. Finally, the model suggests theoretical reason to expect riparian disputes involving a democratic downstream state to be less likely to experience an escalated conflict.

Introduction

As the scarcity of fresh water becomes more and more acute in various regions of the world, the possibility that water supplies become the object of violent interstate conflict will increase. Faced with increasing demand and decreasing supply of water, nation states will come to view access to fresh water as a matter of national security. Indeed, soon after signing the Camp David Accords with Israel, Egyptian President Anwar Sadat proclaimed, "the only matter that could take Egypt to war again is water" (quoted in Starr 1991, p. 19). As such, a state's threat to limit another state's access to fresh water could reasonably be perceived as a threat to its national security. In response to such threats, states will consider an array of options to defend their security, including the use of military force.

Concerns about the connections between scarcity of natural resources and the prospects for interstate and intrastate conflict has driven a number of scholarly

investigations into these issues. Gleick (1993), Homer-Dixon (1991, 1994) and Starr (1991) examine the relationship between competition for scarce fresh water resources and international conflict. Beach et al. (2000) provide a comprehensive overview of some of the issues involved in resolving international disputes involving freshwater resources. Gleick (1990), Hall and Hall (1998), Lipschutz (1989), Mathews (1989), Westing (1986), and Ullman (1983) provide broader examinations of the relationship between natural resource scarcity and international security.

This study addresses a specific set of questions about the likelihood of an escalation in conflict between two states that share water resources from a river flowing through both countries. The study uses game theory to model interactions between the two states. The upstream riparian in the model considers limiting the downstream riparian's access to water through some type of diversion or alteration of the river flow. Herein, we will refer to this upstream diversion project as the construction of a dam, but the interpretation of the model we present can include other types of upstream activities (e.g. a new source of upstream pollution, diversion of water for irrigation purposes, etc.). The model will lead to a number of conclusions which will be helpful in answering a range of important questions about riparian disputes over international riverways. Under what circumstances could disputes over upstream diversions lead to an escalation in the conflict, including the possibility of violent military conflict? In which circumstances are riparians willing to negotiate and agree to settlements involving compensation packages to the downstream state in return for losses in access to water? When are upstream states likely to be deterred from pursuing diversion projects altogether and permit the status quo to continue?

The model we develop includes four distinct possible outcomes: (1) the status quo, (2) construction of a dam on the upstream country's territory, (3) an escalated conflict, and (4) a negotiated settlement involving the construction of an upstream dam with compensation to the downstream actor. We provide a theoretical delineation of several different classes of upstream and downstream states in terms of their preferences for these outcomes. All of the classes of upstream states we examine prefer the construction of the upstream dam most. As we explain in more detail below, however, we are not interested in examining the behavior of a class of upstream states that would prefer an escalated conflict with the downstream state over a negotiated agreement and the status quo. Such an upstream state faces an especially dire circumstance. Water shortages have become so acute that national security is severely threatened. If the downstream state is resolved to block the upstream country's intention of constructing a dam, the upstream state would prefer an escalated conflict rather than accept the status quo or a negotiated compromise.

The classes of actors we examine have not reached this stage of severe water shortage. For many of the actor types we analyze, the status quo and a negotiated settlement are acceptable alternatives to unilateral construction of an upstream dam. At the same time, some of the upstream actor types we examine remain willing to risk an escalated conflict as they pursue plans to construct a dam. In short, we examine the behavior of riparians before the stages where acute water shortages make upstream states so desperate that an escalated conflict is the only other acceptable alternative short of building a dam on their own territory. By focusing on these classes of upstream states, we aim to shed light on the factors which make riparians more or less likely to seek out

negotiation as a means to settling their dispute before water scarcity becomes so severe that these alternatives become untenable. Before proceeding to a discussion of the model, let us offer a brief discussion to provide more detail about what negotiation and escalated conflict entail in the context of riparian interactions.

Riparian negotiation and conflict

In the model presented below, the negotiation process produces a settlement where the upstream state compensates the downstream state for losses in access to water. These losses could be due to increased river pollution due to upstream industrial or agricultural activities. Or, the losses could be due to reduced flow caused by the construction of an upstream hydroelectric facility. Historically, many neighboring riparians have negotiated settlements involving some form of compensation for the downstream actor. Beach et al. (2000) provide a brief overview of the form of some of these negotiated agreements. For example, under the terms of the 1972 Vuoksi River Agreement, the USSR provides Finland with approximately 20,000 MWH of hydroelectric power to compensate Finland for reduced power-generating capacity as a result of construction of a hydroelectric dam on the USSR portion of the river. The 1929 Nile Waters Agreement illustrates how a third-party can facilitate agreement by rewarding disputing riparians for agreeing to a settlement. The agreement between Egypt and Sudan included compensation for both actors from Great Britain which provided both actors with technical assistance in exchange for agreeing to a negotiated settlement on water allocation.

International organizations, both IGO's and NGO's, have an important role to play in the negotiation process. These organizations can help in the collection and sharing of data in order to bring clarity to disputed issues so that mutually beneficial solutions become apparent. In the model below, the actions of third parties are not explicitly included in the negotiation process. Rather, the process is modeled strictly from the perspective of the state actors. We assume that if both actors embrace the negotiation process, a proposed settlement of some kind will be produced. Whether this settlement will be acceptable to the actors, however, depends ultimately on the actors preferences. For some of the classes of upstream riparians we examine, the negotiated settlement will represent an improvement over the status quo, but for others it will not.

In some circumstances, upstream actors will reject negotiations when they believe a negotiated settlement will make them worse off than other options they might pursue. Indeed, if the downstream actor is expected to back down when negotiations fail, the upstream actor may be able to construct its dam without any compensation to the downstream neighbor. This course of action risks the possibility of escalated conflict, especially if the downstream actor turns out to be more resolved to oppose the upstream state's efforts.

If the upstream state refuses to negotiate, the downstream country faces a choice between backing down and allowing the construction of the dam or pursuing further options which may risk an escalated conflict. In practice, these options include the imposition of non-military sanctions (i.e. diplomatic or economic sanctions), a public condemnation of the upstream state's intentions, or mobilization of the military to attempt

to block the upstream country's efforts to construct the dam. Each of these options carry the risks of an escalated conflict with the upstream state.

The attractiveness of these escalatory choices, including the possibility of using military force, depends on a number of factors. These include the extent of the state's military capabilities, the domestic populace's support for an escalated conflict (and possible military hostilities with the neighboring state), and expected costs for an escalated conflict. Depending on the arrangement of these factors, some states may view an escalated conflict with a threatening upstream state more favorably than allowing the construction of a water project. Others, because the resolve for using force is weak, may view acquiescing to the construction of the project more favorably.

This dichotomy between those states who are willing to risk an escalated conflict rather than allow a restriction in water use and those who are not will serve as a critical feature of the interactions between disputants in riparian conflicts. Many theorists of international relations have argued that a critical determinant of a nation's willingness to use force hinges on the distribution of power between the adversaries (Waltz 1979, Organski and Kugler 1980, Bueno de Mesquita 1981, Bueno de Mesquita and Lalman 1989, Bremer 1992). Moreover, in studies focusing specifically on riparian disputes, scholars have asserted that the balance of power between adversaries is a key factor in explaining whether the dispute will be settled peacefully or escalate violently. Gleick has argued that the characteristics of a dispute which are most likely to affect the intensity of a riparian conflict include "...the relative power of the basin states" (1993, pp. 84-85). Homer-Dixon (1994, p. 19) also argues that the downstream actor's resolve to use force will play a critical role in the likelihood of escalated conflict between riparians. The

model we present below will help to shed light on the relationship between the actors' resolve and willingness to risk an escalated conflict and the respective likelihood of negotiated settlement or further conflict.

The Model

The analysis in this study proceeds from an extensive form game theoretic model. The international riparian game (depicted in Figure 1) is a model of interactions between two disputing riparians: an upstream country (u) and a downstream country (d). The model begins at node 1 where u makes a choice between initiating plans to construct a dam or not (D_u or $\sim D_u$). If u chooses not to initiate the construction of a dam, the game ends and the status quo (SQ) is the outcome. When u chooses to initiate the construction of a dam, the downstream country d responds with a decision at node 2. At node 2, d can choose to demand that u negotiate this matter with d, N_d . The interpretation of this move is that d, by demanding to negotiate, opposes u's attempt to unilaterally construct the dam without an effort to accommodate d's interests. Alternatively, d may choose not to demand negotiations and, thus, resist active opposition to construction. The choice not to demand negotiations is denoted $\sim N_d$. When d chooses $\sim N_d$ at node 2, the game terminates and the outcome is u's unilateral construction of the dam (denoted DAM).

At node 3, u responds to d's demand to negotiate over the matter of constructing an upstream dam. By agreeing to negotiate, N_u , u initiates a negotiation process which will yield a settlement package whereby the downstream actor is compensated in some form for the construction of an upstream dam. One interpretation of this negotiation process is that representatives of the disputing states (conceivably with the help of

representatives from international governmental organizations, non-governmental organizations, and other experts such as hydrologists and engineers) investigate the possible outcome space to the dispute to search for mutually profitable solutions. Thus, negotiations offer riparians the opportunity to discover mutually beneficial settlements to the dispute. In the model, these negotiations produce a settlement package that involves the construction of an upstream dam plus some level of compensation to d in exchange for the costs it endures due to the restrictions it would suffer in the use of the river's water. This outcome is denoted DAM^* . At node 4, d makes a choice between accepting the final negotiated package, ACC_d , or rejecting it, REJ_d . We assume that d always prefers DAM^* to a dam which is unilaterally constructed by u (DAM). Naturally, u prefers DAM over DAM^* .

Returning to node 3, u may also chose to simply reject d 's demand to negotiate over the matter and renew its intention to unilaterally build the dam. In this case, d is confronted with a choice at node 5. Here, d can attempt to block (B_d) the effort to build a dam. We label the outcome to such a decision by d as an escalated conflict (denoted C). In this move, d chooses to actively oppose the dam's construction. The interpretation of this choice may involve the use of military force, but not necessarily. Alternatively, the choice may entail the imposition of sanctions, mobilization of troops to border positions, or appeals to the global community to help stop the upstream state's actions. To be clear, our interpretation of the choice to block u 's efforts, B_d , is that it leads to an outcome where conflict tensions have escalated and where the risks of a military exchange have heightened. At node 5, d may also chose to back down and chose not to block the dam's construction, $\sim B_d$. When d chooses $\sim B_d$ at node 5, the outcome to the game is DAM^{BD} .

Like the outcome at node 2 when d chooses $\sim N_d$, DAM^{BD} is the unilateral construction of an upstream dam without compensation to d . Unlike the outcome that stems from node 2, however, DAM^{BD} is assumed to involve costs for the downstream state associated with backing down from its demands on u . When d chooses to demand negotiations over the matter at node 2, it has publicly staked its claims about its interests in any upstream water diversion. From that point on in the game, backing down to the upstream actor is more costly. For example, these costs may come in the form of domestic political costs where the mishandling of this foreign policy issue with u has bolstered the support of domestic political opponents. For simplicity in the model, the upstream actor is indifferent between DAM and DAM^{BD} . We assume the downstream actor has a slight preference for DAM over DAM^{BD} .

If d rejects the negotiated settlement package at node 4, u must make a decision at node 6. At node 6, u may abandon its plans to build a dam, $\sim D_u$, which will terminate the game at the status quo (SQ), or u may decide to renew its plans to build a dam, D_u . If u makes the latter choice, the game proceeds to node 7. The choice at node 7 for d is similar to the choice it makes at node 5. It must choose between blocking u 's attempts at dam construction, B_d , or backing down and permitting the construction of the dam, $\sim B_d$. The former choice terminates the game with escalated conflict (C); the latter choice terminates the game at DAM^{BD} .

Before turning to an analysis of how rational decision makers would behave in this game, let us discuss some restrictions on the preferences held by the actors over the

game's possible outcomes. First, we assume that u will always prefer DAM over an escalated conflict, C . To assume otherwise would imply a consideration of cases where u simply wants to engage in conflict with d , regardless of its particular valuation for constructing a dam. Obviously, these cases are not of interest for this study. Secondly, let us assume that u prefers DAM to the status quo, SQ . Finally, as described above, we assume u prefers DAM to DAM^* . The downstream country prefers the status quo, SQ , to the construction of the dam. No conflict exists between the nations if d prefers the DAM to the SQ . We assume d prefers the SQ to escalated conflict, C . Again, we assume this to avoid consideration of cases where d simply wants to engage u in heightened conflict without regard to the issue of water. Finally, as we discussed above, d prefers DAM^* to DAM.

(Table 1 about here)

With these restrictions on preferences, the set of possible preference orderings over the outcome space reduces dramatically. The restrictions leave only 6 possible orderings for u and 4 orderings for d . These preference orderings are listed in Table 1. Each of the 6 orderings for u , and 4 preferences for d defines a unique *player type*.¹ In the model considered here, there are 6 different types for u , $\{u_1, u_2, \dots, u_6\}$, and 4 for d , $\{d_1, d_2, d_3, d_4\}$.

In Table 1, the player types are classified into smaller groupings which are given labels for convenient reference throughout our discussion. Upstream types u_1 and u_2 are labeled "relenters." Like all upstream types considered here, the upstream relenters

¹ In game theoretic terms, a player's *type* can be defined by his payoff function (preferences), strategy options available to him, or by the information available to him throughout the game. For a more detailed discussion, see Rasmusen (1989, p. 55).

prefer DAM most. The second-preferred outcome for relenters is the status quo. When this upstream type views the prospects for achieving DAM as unlikely, it can be expected to relent in its challenge of the downstream actor and settle for the status quo. Upstream types u_3 and u_4 are labeled “negotiators.” While DAM is valued highest by these actors, the negotiated outcome DAM* is valued second-highest. These two upstream types are the only actors who prefer the negotiated outcome over the status quo and conflict. Finally, upstream types u_5 and u_6 are labeled “fighters.” These actors prefer conflict second-highest to DAM. These actors can be expected to make choices in the riparian game which force the downstream actor to choose between DAM and C. Consequently, little attention will be paid to the behavior of upstream fighters in this study. Their behavior in the model examined below is straightforward—they will not accept the status quo or a negotiated settlement as an outcome to the game. They are expected to press their demands to build a dam to the point where the downstream actor simply agrees to the dam's construction (at node 2). Or, if the downstream actor does not choose $\sim B_d$ at node 2, the upstream fighters will force the downstream actor into a choice between accepting the construction of the dam or blocking construction through an escalation of the conflict (at nodes 5 or 7).

We label the downstream types either “strong” (d_1 and d_2) or “weak” (d_3 and d_4). We label downstream actor types d_3 and d_4 “weak” to underline their particular resolve for conflict. Although the construction of a dam represents a deterioration of the status quo, the weak downstream state is not in a position to employ military force as an instrument to protect national goals. For a number of possible reasons, the risks inherent in heightened, militarized tensions with u are valued even less than the deterioration of

the status quo that would be endured as a result of the dam's construction. Perhaps d 's military capabilities are known to be inferior to u 's or domestic political costs for conflict are estimated as being too great. In short, downstream states d_3 and d_4 are said to have weak resolve for opposing u 's efforts to build a dam and this manifests itself in a preference where DAM is preferred to C. We label downstream types d_1 and d_2 "strong" because their resolve to use force to block construction of the dam is stronger than types d_3 and d_4 . Although conflict is less preferred than the status quo for each of these types, they would prefer to fight rather than permit construction of the dam.

To ease computation throughout the analysis, we normalize the utility values associated with each of the outcomes in the game. For all upstream types, the utility value for DAM is equal to 1. Further, as discussed above, we assume the upstream actor is indifferent between DAM and DAM^{BD} , $U_u(DAM)=U_u(DAM^{BD})=1$. The utility value for the status quo is set to 0, $U_u(SQ)=0$. For upstream actors, this implies that the utility values for outcomes preferred less than the status quo are negative. We do not make assumptions about the lower bound for outcomes valued less than SQ for upstream actors. For all downstream types, the utility value for SQ is set to 1, $U_d(SQ)=1$, and the utility value for DAM is set to 0, $U_d(DAM)=0$. As discussed above, we assume that the utility value for DAM^{BD} is slightly less than the value for DAM. For weak downstream types (d_3 and d_4) we assume that $U_d(DAM^{BD})>U_d(C)$.

Equilibrium Analysis

We analyze the model presented in the previous section by considering various pairings of actor types one at a time. We examine a number of different circumstances where the two countries possess substantial information about the preferences and

interests of the other, but where that information remains incomplete. We assume that in the events leading up to the interaction described in the model, the downstream state, d , has gathered sufficient information about the upstream country, u , such that d possesses complete information about u 's preference ordering over the five possible outcomes to the game. The upstream country possesses incomplete information about d 's preferences. In particular, u possesses all information about d 's preferences except its preference between C and DAM. Thus, u does not know with certainty whether d is strong or weak. By virtue of this knowledge, the upstream country can narrow the possible set of downstream country types it faces to a set of two. For any given game, the set of possible downstream player types is either $\{d_1, d_3\}$ or $\{d_2, d_4\}$. At the outset of any given game, the upstream actor holds a probabilistic belief that the downstream actor is strong (i.e. that the downstream country's type is either d_1 or d_2 , depending on the pairing). We denote this probability λ , such that $0 < \lambda < 1$.

We examine the model by beginning with a consideration of the upstream negotiators (upstream types u_3 and u_4). We explore the expected behavior of these actors when they believe they confront a pairing of d_1 and d_3 or a pairing of d_2 and d_4 . Then, we consider the dynamics of the game when the upstream country is a so-called relenter (upstream types u_1 and u_2).

Upstream Negotiators

The behavior of upstream actors, relenters and negotiators alike, depends heavily on their beliefs about the downstream country's resolve to block construction of the dam, B_d , through an escalation of the conflict. It will be shown that as u 's beliefs that d is

strong (λ) increase, u becomes increasingly less willing to make choices in the game that lead to either nodes 5 or 7. At these nodes, d is forced into a decision between backing down and permitting the dam's construction ($\sim B_d$) or blocking the construction with an escalation of the conflict (B_d). To appreciate how the upstream actor makes decisions based on its initial beliefs, let us explore equilibrium behavior in one particular game involving an upstream negotiator. Many of the insights gained in this game can then be applied to other possible games involving different combinations of actor types.

Let us consider a game between upstream negotiator u_4 and a downstream country. As we discussed above, let us assume that the upstream actor does not know the downstream actor's preference between C and DAM , but does know its preferences in connection with all other possible outcomes in the game. As a result, u_4 has narrowed down the possible downstream types to either d_2 or d_4 . The downstream actor's actual type is private information known only to d . The upstream actor estimates the probability that the d 's type is d_2 with probability λ and estimates the probability that d 's type is d_4 as $1-\lambda$. Let us examine two equilibria that can be supported with this combination of actor types. The Appendix fully describes both equilibria (Equilibrium 1 and 2).

We begin by considering the terminal nodes first and proceeding by backwards induction. At node 7, it is clear that d_2 would choose B_d since it prefers C to DAM^{BD} . Since d_4 prefers DAM^{BD} to C , it chooses $\sim B_d$. At node 6, u_4 chooses D_u because both of the possible outcomes to that choice (C and DAM^{BD}) are preferred to the SQ . At node 4, the downstream actor chooses between accepting the negotiated settlement package and rejecting it. If the downstream actor chooses ACC_d , the outcome to the game is DAM^* . If the downstream actor rejects the settlement, the outcome to the game depends on the

downstream actor's type. If the downstream actor is d_2 , the eventual outcome to the game if it chooses REJ_d at node 4 is C. If downstream's type is d_4 , the eventual outcome is DAM^{BD} . In both cases, whether the downstream actor is d_2 or d_4 , DAM^* is preferred to the eventual outcome that would result if downstream chose REJ_d at node 4. Hence, the best reply at node 4 for both downstream types is ACC_d .

At this point in the analysis of the game, it can be seen that the outcome to the game is clear if the players' choices lead to node 4. The outcome would be DAM^* , the negotiated settlement. For the game to reach node 4, the upstream actor must agree to negotiations (N_u) at node 3. Since u_4 possesses incomplete information about d 's type, u_4 's decision depends heavily on its beliefs about the probability that the downstream actor is d_2 or d_4 . Let $\bar{\lambda}$ denote u_4 's updated belief at node 3 that downstream's type is d_2 . What value must $\bar{\lambda}$ take in order for u_4 to be indifferent between N_u and D_u ? By setting the expected values for N_u and D_u equal to each other and solving for $\bar{\lambda}$, we have

$$\bar{\lambda}(U_u(C)) + (1 - \bar{\lambda})(1) = U_u(DAM^*)$$

which reduces to

$$\bar{\lambda} = \frac{1 - U_u(DAM^*)}{1 - U_u(C)} = \bar{\lambda}_{crit} \quad (1)$$

The expression defines a threshold level for $\bar{\lambda}$, which we denote $\bar{\lambda}_{crit}$. When $\bar{\lambda}$ is greater than $\bar{\lambda}_{crit}$, u_4 chooses N_u . In this circumstance, u_4 estimates a sufficiently high probability that the downstream state is strong such that rejecting negotiations leads to a high risk of escalated conflict. Consequently, since expectations are higher for negotiations, u_4 chooses N_u . When $\bar{\lambda}$ is less than $\bar{\lambda}_{crit}$, u_4 chooses D_u .

At node 2, the downstream actor's choice depends on its expectations about u_4 's move at node 3. The strong downstream actor (d_2) prefers C over DAM (or DAM^{BD}). Thus, a strong downstream actor will always choose to demand negotiations (N_d) at node 2. For the weak downstream actor (d_4), N_d would be preferred if it were known that u_4 would chose N_u at node 3. Otherwise, it would prefer to choose $\sim N_d$ at node 2 (leading to DAM) rather than back down at node 5, which would lead to the more costly DAM^{BD}. Let p denote the probability that u_4 rejects negotiations at node 3. What value of p makes d_4 indifferent between choosing $\sim N_d$ and N_d at node 2? We find this value of p in the following manner

$$p(U_{d_4}(DAM^{BD})) + (1-p)(U_{d_4}(DAM^*)) = U_{d_4}(DAM) = 0$$

Solving for p , we have

$$\frac{U_{d_4}(DAM^*)}{U_{d_4}(DAM^*) - U_{d_4}(DAM^{BD})} = p \quad (2)$$

If the upstream actor adopted a mixed strategy that rejected negotiations (D_u) at node 3 with probability p (and chose N_u with probability $1-p$), the weak downstream actor would be indifferent between N_d and $\sim N_d$ at node 2. For the upstream actor to play such a mixed strategy, it must be indifferent between N_u and D_u , which would require that it hold beliefs about downstream's type equal to $\bar{\lambda}_{crit}$. The weak downstream actor's mixed strategy that creates u_4 's beliefs $\bar{\lambda}_{crit}$ can be found by using Bayes' Rule. Let q denote the probability that d_4 demands negotiations (N_d) at node 2. Bayes' Rule gives u_4 's updated belief about downstream's type as

$$\bar{\lambda}_{crit} = \frac{pr(d_2)pr(N_d | d_2)}{pr(d_2)pr(N_d | d_2) + pr(d_4)pr(N_d | d_4)}$$

Substituting q for the probability that d_4 demands negotiations and substituting other known values,

$$\bar{\lambda}_{crit} = \frac{\lambda(1)}{\lambda(1) + (1-\lambda)q}$$

and substituting the value for $\bar{\lambda}_{crit}$ from expression (1),

$$\frac{1-U_u(DAM^*)}{1-U_u(C)} = \frac{\lambda(1)}{\lambda(1) + (1-\lambda)q}$$

and solving for q , we have

$$q = \frac{\lambda(U_u(DAM^*) - U_u(C))}{(1-U_u(DAM^*))(1-\lambda)}$$

It can be seen that in order for q (a probability) to be less than 1, it must be true that $\lambda < \bar{\lambda}_{crit}$. That is, in order for a mixed strategy of this kind to be supported in equilibrium, $\lambda < \bar{\lambda}_{crit}$ is a necessary condition. The first equilibrium described in the Appendix is based on this condition. When $\lambda < \bar{\lambda}_{crit}$, d_4 adopts a mixed strategy such that it chooses N_d at node 2 with probability q and $\sim N_d$ with probability $1-q$. Upstream actor u_4 adopts a mixed strategy such that it chooses D_u with probability p and N_u with probability $1-p$. When $\lambda < \bar{\lambda}_{crit}$, four equilibrium outcomes are possible in the game: DAM with probability $(1-\lambda)(1-q)$, DAM^* with probability $\lambda(1-p)+q(1-\lambda)(1-p)$, C with probability λp , and DAM^{BD} with probability $(1-\lambda)p$.

When $\lambda > \bar{\lambda}_{crit}$, a mixed strategy cannot be supported. In that case, the weak downstream actor d_4 should always choose to demand negotiations in equilibrium. When $\lambda > \bar{\lambda}_{crit}$, d_4 benefits from u_4 's high initial beliefs that the downstream country is strong.

When $\lambda > \bar{\lambda}_{crit}$, d_2 and d_4 both choose N_d at node 2. Since both types make the same choice at node 2, $\lambda = \bar{\lambda}$ at node 3. Consequently, since $\lambda > \bar{\lambda}_{crit}$, u_4 's best reply is to choose N_u , which leads to the eventual outcome of DAM^* . This is the necessary condition for the second of the two equilibria to be supported.

Finally, at node 1, the upstream actor u_4 makes a choice between announcing plans to initiate construction of the dam or not. Since the status quo is u_4 's least preferred outcome to the game, it is evident that u_4 's rational choice at node 1 is to announce plan's to build a dam, D_u . All of the possible ways the game could unfold will lead to more preferable outcomes for u_4 than the status quo.

To summarize, the threshold defined by $\bar{\lambda}_{crit}$ plays an important part in determining rational behavior in the game. Figure 2 displays a graphical depiction of the $\bar{\lambda}_{crit}$ function for upstream actors. The upstream actor's utility values for conflict are depicted on the front axis. The utility values for the negotiated settlement, DAM^* , are located on the right side of the box. When λ is located above the plane depicted in the figure (i.e. when $\lambda > \bar{\lambda}_{crit}$), the condition has been satisfied for the upstream actor to agree to negotiations at node 3. It can be seen that $\bar{\lambda}_{crit}$ decreases with increases in $U_u(DAM^*)$. This relationship is intuitive. As the upstream actor's valuation for the negotiated settlement increases, its beliefs that d is strong can take increasingly lower values in order to satisfy the threshold condition. The threshold reaches its lowest values when the upstream actor's valuation for DAM^* approaches 1 and its value for conflict approaches the lowest values in the indicated range. When values for conflict are greater than values for DAM^* (in the back right corner of the box), the threshold value $\bar{\lambda}_{crit}$ exceeds 1. Since

the value of conflict does not exceed the value of DAM^* for the upstream negotiators, these values do not have meaning in the context currently under consideration. Overall, this relationship in the model implies a highly intuitive proposition that as the upstream country's value for a negotiated settlement increases with respect to the value for conflict, negotiated settlements are more likely.

(Figure 2 about here)

Although the upstream negotiators value the negotiated settlement more than the SQ, it can be seen that the negotiated settlement DAM^* is certainly not guaranteed.

Indeed, an escalated conflict is a possibility, with probability $\lambda(p)$, whenever $\lambda < \bar{\lambda}_{crit}$.

This equilibrium describes a situation where u_4 holds relatively low prior beliefs that the downstream actor is resolved to use force (i.e. that downstream is type d_2).

Consequently, u_4 's best reply at node 3 is a mixed strategy which plays D_u with probability p . Indeed, it can be seen by examining expression (2) that probability p can be quite high when there is little difference to a downstream actor between conceding to DAM at node 2 and backing down later at node 5 (DAM^{BD}).

In situations where the downstream actor loses relatively little by publicly announcing its dissatisfaction with upstream's intentions and then backing down later (for example, when domestic political costs are minimal), the likelihood of escalated conflict is potentially higher. Facing states that lose little from backing down and accepting DAM^{BD} , upstream states must continue to reject negotiations with a high probability in order to maintain the downstream state's indifference at node 2. When u_4 knows that the costs of backing down are substantial for weak downstream states, it can afford to reject negotiations in equilibrium with a lower probability p . This observation yields an

interesting insight about how the regime types of riparians may play a role in the prospects for conflict and negotiation. One might reasonably argue that leaders of non-democratic governments are more likely to experience lower domestic political costs for foreign policy failures. For non-democratic downstream states, the difference between DAM and DAM^{BD} may not be as large as it is for democratic downstream states. As a result, there is theoretical reason to expect the likelihood of negotiated settlements to be higher when the downstream state is democratic. In the concluding section, we offer a broader discussion regarding the possibility that democratic downstream states may avoid escalated conflicts with upstream neighbors more effectively.

To what extent does the logic described above apply for the other upstream negotiator u_3 and the other pair of downstream types d_1 and d_3 ? The logic of the above analysis pertains to all of the possible combinations of upstream negotiators and downstream types with one exception. In nearly all of the combinations, $\bar{\lambda}_{crit}$ continues to define a critical threshold. In situations where $\lambda < \bar{\lambda}_{crit}$, the downstream and upstream actors adopt the same mixed strategy described above. Consequently, the same four outcomes (DAM, DAM^{BD}, C, and DAM^{*}) can result in equilibrium in those settings. When $\lambda > \bar{\lambda}_{crit}$, DAM^{*} is the outcome with one important exception which we now describe.

Notice that upstream negotiator u_3 prefers the SQ over C. This stands in contrast to upstream negotiator u_4 , who found the SQ to be so unacceptable that it preferred an escalated conflict. This difference in preference opens up the possibility that the SQ could evolve as an equilibrium outcome to the game when u_3 believes it confronts d_2 or d_4 in the game. Notice that downstream types d_2 and d_4 prefer the SQ over all other

outcomes. At node 4, if these downstream actors could be sure that u_3 would accept the SQ at node 6, it would be rational to reject the negotiated settlement DAM^* and advance the game to node 6. At node 6, u_3 prefers to abandon construction of the dam, $\sim D_u$ whenever the SQ is valued higher than the expected value of D_u or when

$$U_u(SQ) > \bar{\lambda}(U_u(C)) + (1 - \bar{\lambda})(U_u(DAM^{BD}))$$

which, after substituting a zero for the value of the SQ, reduces to

$$\bar{\lambda}_{crit} > \frac{1}{1 - U_u(C)} \quad (3)$$

When $\lambda > \bar{\lambda}_{crit}$, the downstream actor chooses to reject the negotiated settlement DAM^* in anticipation that u_3 will abandon its plans to construct the dam and choose $\sim D_u$ instead.

With these information conditions in this game, u_3 is indifferent between choosing $\sim D_u$ at node 6 or choosing $\sim D_u$ at node 1. Since both downstream types make the same choices throughout the game in this equilibrium, the upstream actor does not get an opportunity to update its beliefs. Consequently, $\lambda = \bar{\lambda} = \bar{\lambda}$. The Appendix contains a full description of this third equilibrium (Equilibrium 3).

The analysis of the game when the upstream actor is a negotiator has yielded a number of insights. First, as the upstream actor's beliefs that the downstream actor is strong (λ) increase, the likelihood of a negotiated settlement DAM^* increases. Second, as the upstream country's valuation of DAM^* increases with respect to its valuation for conflict, the likelihood of a negotiated settlement DAM^* increases. Third, as the difference between DAM and DAM^{BD} diminishes for a downstream country, the probability that the upstream actor rejects negotiations at node 3 increases.

Consequently, the probability of escalated conflict increases. Fourth, the status quo is

possible in games involving upstream negotiators, but only when $\lambda > \bar{\lambda}_{crit}$ and when downstream prefers the SQ over DAM* (types d_2 and d_4).

Upstream Relenters

Of all the possible outcomes in the game, upstream relenters prefer the unilateral construction of a dam without compensation to the downstream country most. In this regard, they are not different from the upstream negotiators. Unlike the negotiators, the relenters prefer the SQ over a negotiated settlement DAM*. If relenters agree to a settlement whereby they must compensate the downstream actor in exchange for construction of a dam, the resulting outcome will be valued less than the status quo. Upstream relenters must anticipate the risks and possibilities associated with announcing plans to construct a dam at node 1 and evaluate whether the expectations from such a decision outweigh the value of the status quo. If those expectations do not exceed the value of the status quo, these upstream countries are expected to relent from their plans to build a dam. Let us explore the expected behavior of upstream relenters beginning with type u_1 .

We begin by considering a game where u_1 estimates the downstream actor's type as d_2 with probability λ and estimates its type as d_4 with probability $1-\lambda$. A description of one of the equilibria for this game is offered in the Appendix (Equilibrium 4). In this game, the upstream country's beliefs about the downstream country's type will affect its willingness to press its demands to build a dam at node 1. Let us begin by considering u_1 's decision at node 6 and proceeding by backwards induction.

From expression (3), it can be seen that u_1 will choose D_u whenever $\lambda < \bar{\lambda}_{crit}$.

When $\lambda < \bar{\lambda}_{crit}$, the best reply for downstream types d_2 and d_4 is ACC_d at node 4². At node 3, u_1 chooses between agreeing to negotiations (which will result in DAM^*) or rejecting negotiations and continuing plans to construct a dam unilaterally, D_u . Since u_1 prefers both possible outcomes which could result from the latter choice over DAM^* , u_1 's best reply is D_u . At node 2, d_2 prefers N_d because the anticipated outcome from this choice (an escalated conflict with u_1 , C) is preferred over DAM . For d_4 , however, DAM is preferred over DAM^{BD} and thus prefers to back down at node 2 ($\sim B_d$) rather than insist on negotiations. Finally, at node 1, u_1 will initiate plans for the dam, D_u , whenever the following expression is true.

$$\lambda < \frac{1}{1 - U_u(C)} \quad (4)$$

The right-hand side of the expression is equivalent to $\bar{\lambda}_{crit}$. This is not surprising given that u_1 faces a choice at node 1 which is identical to the choice at node 6. It chooses between accepting the SQ or pressing its demands. If u_1 chooses D_u and the downstream actor is strong, the outcome will be an escalated conflict. If the downstream actor is weak, the outcome will be DAM . Finally, notice that this threshold condition implies that as the value for conflict decreases for u_1 , it must be increasingly confident that the downstream country's type is weak (d_4) before choosing D_u at node 1. When there is little difference between the value for conflict and the SQ (recalling that the value of the

² It can be seen that this stage of the game is off the equilibrium path. We invoke the passive conjectures assumption about out-of-equilibrium beliefs (Rasmusen 1989, p. 114) and assume that the probability of d_2 choosing REJ_d at node 4 is equal to initial prior beliefs λ . Since $\lambda < \bar{\lambda}_{crit}$, u_1 can be expected to choose D_u at node 6.

SQ is fixed at 0 for all upstream types), u_1 will become increasingly willing to choose D_u even when it believes that the downstream country is likely to be strong. Put differently, as the value of SQ worsens with respect to the value for escalated conflict, u_1 becomes increasingly willing to initiate the dam construction at the risk of escalated conflict.

The logic of this equilibrium also holds for games when u_1 believes it confronts downstream type d_1 and d_3 . The critical threshold described in expression (4) determines whether u_1 will choose to initiate the game by choosing D_u or whether it will accept the status quo. If u_1 chooses D_u the outcome to the game will be an escalated conflict C whenever the downstream actor is strong (d_3). Otherwise, the outcome will be DAM if the downstream actor is weak.

For upstream relenters u_2 , equilibrium behavior in the game is different (see the Appendix for a description of equilibrium behavior for upstream type u_2). Let us begin by considering an equilibrium where initial beliefs are such that $\lambda < \bar{\lambda}_{crit} < \bar{\bar{\lambda}}_{crit}$. With these information conditions, the equilibrium moves in the game from node 2 onward are the same as in the previous games involving upstream negotiators where beliefs take this same structure. At node 1, the upstream type makes a comparison between the expected value of choosing D_u at node 1 and $\sim D_u$, which leads to the SQ. Given the mixed strategies adopted at nodes 2 and 3 by the two actors, the expected value of choosing D_u at node 1 can be expressed as

$$EV_u(D_u) = \lambda(U_u(DAM^*)) + (1 - \lambda)[q(U_u(DAM^*)) + 1 - q]$$

When $EV_u(D_u) > SQ$, u_2 's choice at node 1 is D_u . It can be found that $EV_u(D_u) > SQ$ whenever,

$$\frac{q(U_u(DAM^*) - 1) + 1}{q(U_u(DAM^*) - 1) + 1 - U_u(DAM^*)} > \lambda \quad (5)$$

The left hand side of expression (5) defines an additional threshold condition under which u_2 's belief that the downstream country is strong (λ) must lie in order for it to choose D_u at node 1. It may be instructive to consider a graphical depiction of this threshold condition to see how it relates to values of $U_u(DAM^*)$ and q (the probability that a weak downstream country would demand negotiations at node 2.) Looking at Figure 3, it can be seen that as the value of DAM^* increases (from the front of the box to the back) for u_2 , the threshold condition increases in value. Thus, as the difference diminishes between u_2 's valuation of the negotiated settlement and the SQ (with a value of 0 for upstream types), the likelihood of satisfying the conditions for beginning the game with D_u increase.

(Figure 3 about here)

It can also be seen that as the probability of a weak downstream country demanding negotiations at node 2 increases (from the left of the box to the right) the threshold also declines. This relationship is especially intuitive. The only outcome u_2 values more than the SQ is DAM (or DAM^{BD}). As a weak downstream state becomes more likely to demand negotiations at node 2 (i.e. as q increases), the overall likelihood of achieving DAM as the final outcome to the game diminishes. The result is a decline in the expected value for choosing D_u at node 1.

Overall, the condition is easiest to satisfy when the value of DAM^* is at its highest for u_2 and when the probability that a weak downstream actor will demand negotiations is at its lowest. In general, the upstream relenter u_2 is increasingly likely to accept the status

quo the higher its beliefs that the downstream actor is strong. Conversely, when it estimates a probability λ less than the additional threshold described in expression (5), u_2 initiates the game by choosing D_u . This induces both actors to invoke their mixed strategies at nodes 2 and 3, which can produce DAM, DAM^{BD}, C, or DAM* as outcomes to the game.

When beliefs take the form $\bar{\lambda}_{crit} < \lambda < \bar{\bar{\lambda}}_{crit}$, behavior in the game simplifies considerably. Since the upstream actor's beliefs about the downstream actor's type exceed $\bar{\lambda}_{crit}$, both downstream types will demand negotiations at node 2. The upstream actor will not be able to update its beliefs from the initial λ at node 3. Consequently, its best reply will be to accept negotiations. All downstream types are expected to accept the negotiated settlement. Anticipating this at node 1, u_2 will elect to accept the SQ because it is valued more highly than the negotiated settlement DAM*.

When beliefs take the form $\bar{\lambda}_{crit} < \bar{\bar{\lambda}}_{crit} < \lambda$, behavior is slightly different. Downstream types d_2 and d_4 will reject the negotiated settlement DAM* at node 4 and advance the game to node 6. Since $\lambda > \bar{\bar{\lambda}}_{crit}$ in this case, u_2 is expected to accept the status quo at node 6. This slight change in behavior makes u_2 indifferent between accepting the SQ at node 1 or accepting it later in the game at node 6. Otherwise, when $\bar{\lambda}_{crit} < \bar{\bar{\lambda}}_{crit} < \lambda$, equilibrium behavior in the game is the same as it is when $\bar{\lambda}_{crit} < \lambda < \bar{\bar{\lambda}}_{crit}$.

The analysis of upstream relenters reveals that an escalated conflict is still a possibility—despite the fact that such states prefer the status quo to conflict. When relenters estimate a low likelihood that the downstream state is strong, they may be tempted to initiate plans for the dam's construction. The analysis of the additional

threshold condition (expression 5) suggests that as the difference in value between the SQ and DAM* diminishes, upstream relenters will be increasingly willing to initiate the game by choosing D_u . The negotiated settlement is also a theoretical possibility whenever mixed strategies are invoked. Nonetheless, this equilibrium outcome is somewhat problematic. Upstream relenters prefer the SQ over a negotiated settlement. While DAM* is possible under certain conditions in the model, it would be unrealistic to expect sovereign states to accept a negotiated settlement that makes them worse off than the SQ.

Discussion and Summary

One of the significant contributions made by this study is a theoretical clarification of how increasingly acute water scarcity may contribute to escalated international conflict. Looking again at Figure 2, it can be seen how a worsening status quo contributes to a greater likelihood for escalated conflict. The figure depicts the threshold condition which must be satisfied in order for upstream negotiators to agree to negotiation. The upstream state's beliefs that the downstream state is strong, λ , must lie above the threshold in order to satisfy it. It can be seen that as the value of conflict increases (moving from left to right within the box), the condition becomes increasingly difficult to satisfy. Recall that the value of the status quo for all upstream actors has been set to zero in this study to ease interpretation of the findings. In this way, the relationship depicted in Figure 2 can be described another way. As the value of the status quo worsens with respect to the value for conflict, the upstream state must be increasingly certain that the downstream state is strong before agreeing to negotiations. In this fashion, the game theoretic approach in this study helps to provide greater theoretical clarity to claims that increased water scarcity will increase the chances of international

conflict. A worsening status quo does increase the chances of escalated conflict in this model. Moreover, the model provides insight into which circumstances are particularly likely to be dangerous.

Upstream states falling in the class of 'upstream fighters' are clearly the most dangerous of the six upstream types presented in Table 1. The need for an upstream dam has become so severe for these types of states that they would prefer escalated conflict with the downstream neighbor rather than settle for the status quo or a negotiated compromise involving compensation. When such states confront a strong downstream country, a country that would prefer escalated conflict over construction of an upstream dam, an escalated conflict is very likely.

For the other types of upstream states examined here, the relenters and negotiators, escalated conflict can also be a possibility. The most dangerous situations involving upstream states can be appreciated by glancing again at Figure 2. When upstream negotiators and relenters place a low utility value on the negotiated settlement DAM^* and a relatively high value for escalated conflict, the conditions necessary for the avoidance of conflict become increasingly restrictive. That is, upstream states must be increasingly confident that the downstream state is strong before agreeing to negotiations. This intuitive relationship describes the situations where escalated conflict is most likely.

The upstream state's beliefs, λ , about the downstream actor's resolve also play an important role in shaping the prospects for escalated conflict. The most dangerous situations involving upstream states are ones where they hold a very low likelihood that the downstream state is strong when, in fact, the downstream actor is strong. That is, the situation most likely to produce escalated conflict involves an upstream country holding

mistaken beliefs that the downstream state is likely to back down and permit the construction of a dam when, instead, the downstream actor is strongly resolved to block such efforts. This insight helps to clarify and extend a proposition advanced by Homer-Dixon that riparian "conflict is most probable when a downstream riparian is highly dependent on river water and *is strong in comparison to upstream riparians*" (1994, p. 19, emphasis added). In the model offered here, strong downstream riparians are likely to be involved in an escalated conflict with upstream states, but only when the upstream state holds a 'mistaken' belief that the downstream state is likely to be weak. When the upstream state believes the downstream state is likely to be strong, conflict becomes increasingly less likely. This observation suggests that the avoidance of conflict between upstream states and strong downstream states will depend partly on the downstream state's ability to effectively and credibly signal its resolve. Let us elaborate on this important point because it raises an interesting insight about riparian dispute interactions.

There is compelling reason to believe that some types of states are better than others at effectively communicating their resolve in international confrontations. Fearon (1994) argues that democratic states are better able to signal resolve in interstate confrontations because they are less likely to employ exaggerated bluffs about their resolve and intentions in international disputes. Such 'cheap talk' is less attractive for democratic leaders because their domestic constituency is better able to punish leaders for failing to carry out stated goals, ultimatums, and other claims in foreign policy matters. Thus, when democratic leaders make claims about their resolve in international relations, they are less likely to be discounted by adversaries as cheap talk. This reasoning underlies the theoretical claim that democratic states are better able to signal their resolve

more credibly in interstate interactions. Fearon's arguments can be applied in the context of riparian interactions to generate an interesting conjecture. Riparian interactions involving democratic downstream states may be less prone to escalated conflict due to the strong downstream state's ability to signal its resolve more clearly about its intentions to block an upstream dam. Notice that this point is consistent with the point made earlier about the difference in value between DAM and DAM^{BD} for democracies and non-democracies. Assuming a bigger difference exists for democratic downstream states, the equilibrium analysis suggests a greater willingness on the part of upstream actors to accept negotiations.

The results presented in this study point to the important potential of third parties (NGOs, IGOs, or other state actors) in helping to facilitate negotiations. By improving the value of DAM^* (by subsidizing upstream compensation packages, or by jointly rewarding both riparians for committing to a negotiated settlement) third parties can heighten the possibility of successful negotiations. Great Britain's provision of technical assistance to Sudan and Egypt in the 1929 Nile Waters Agreement is illustrative of productive third-party behavior. Additionally, the model indicates that the prospects for a successfully negotiated agreement diminish when the threatened downstream state lacks the resolve, or is believed to lack the resolve, to escalate the conflict in response to a threat to construct an upstream dam. A lack of resolve can be reasonably interpreted as a manifestation of a disadvantage in military capabilities for the downstream state. Accordingly, this result is consistent with the findings of many scholars who have found that the ability of a third-party to craft a mediated settlement agreeable to disputants is heavily constrained by the power differences among bargainers (Bercovitch 1986, Hewitt

1996, Ott 1972, Young 1967). In general, the bigger the differences in power, the more unlikely it is that a mediator can be successful.

References

- Beach, Heather L., Jesse Hamner, J. Joseph Hewitt, Edy Kaufman, Anja Kurki, Joe A. Oppenheimer, and Aaron T. Wolf (2000) Transboundary Freshwater Dispute Resolution: Theory, Practice, and Annotated References. New York: United Nations University.
- Bercovitch, Jacob (1986). "International Mediation: A Study of the Incidence, Strategies and Conditions of Successful Outcomes," Cooperation and Conflict, Vol. 21, pp. 155-168.
- Bremer, Stuart A. (1992). "Dangerous Dyads: Interstate War, 1816-1965," Journal of Conflict Resolution, Vol. 36, No. 2, pp. 309-341.
- Bueno de Mesquita, Bruce (1981). The War Trap, New Haven, CT.: Yale University Press.
- Bueno de Mesquita, Bruce and David Lalman (1989). "Dyadic Power, Expectations, and War," in Richard J. Stoll and Michael D. Ward (eds.) Power in World Politics, Boulder, CO.: Lynne Rienner Publishers.
- Fearon, James D. (1994) "Domestic Political Audiences and the Escalation of International Disputes" American Political Science Review, Vol. 88, No. 3, pp. 577-592.
- Gleick, Peter H. (1990). "Environment, Resources, and International Security and Politics," in Eric Arnett, ed., Science and International Security: Responding to a Changing World, Washington, DC: American Association for the Advancement of Science, pp. 501-523.
- Gleick, Peter H. (1993). "Water and Conflict: Fresh Water Resources and International Security," International Security, Vol. 18, No. 1 (Summer 1993), pp. 79-112.
- Hall, Jane V. and Darwin C. Hall (1998) "Environmental Resource Scarcity and Conflict," in Murry Wolfson (ed.) The Political Economy of War and Peace, Boston, Massachusetts: Kluwer.
- Hewitt, J. Joseph (1996) The Prospects for Mediating International Disputes, PhD dissertation, University of Maryland.
- Homer-Dixon, Thomas F. (1991) "On the Threshold: Environmental Changes as Causes of Acute Conflict" International Security, Vol. 16, No. 2 (Fall 1991), pp. 76-116.
- Homer-Dixon, Thomas F. (1994) "Environmental Scarcities and Violent Conflict: Evidence from Cases" International Security, Vol. 19, No. 1 (Summer 1994), pp. 5-40.

- Lipschutz, Ronnie D. (1989) When Nations Clash: Raw Materials, Ideology and Foreign Policy, New York: Ballinger Publishing Co.
- Mathews, Jessica Tuchman (1989). "Redefining Security," Foreign Affairs, Vol. 68, No. 2 (Spring 1989), pp. 162-177.
- Organski, A.F.K. and Jacek Kugler (1980). The War Ledger, Chicago, IL.: University of Chicago Press.
- Ott, M. C. (1972) "Mediation as a Method of Conflict Resolution," International Organization, Vol. 26, pp. 595-618.
- Rasmusen, Eric. (1989). Games and Information: An Introduction to Game Theory. Basil Blackwell: Oxford, England.
- Starr, Joyce (1991). "Water Wars," Foreign Policy, Vol. 82 (Spring 1991), pp. 17-30.
- Ullman, Richard H. (1983) "Redefining Security," International Security, Vol. 8, No. 1 (Summer 1983), pp. 129-153.
- Waltz, Kenneth N. (1979). Theory of International Politics, Reading, Mass.: Addison-Wesley.
- Westing, Arthur H. (1986). Global Resources and International Conflict: Environmental Factors in Strategic Policy and Action (ed.), Oxford: Oxford University Press.
- Young, Oran (1967). The Intermediaries: Third Parties in International Crises, Princeton, NJ: Princeton University Press.

Figures

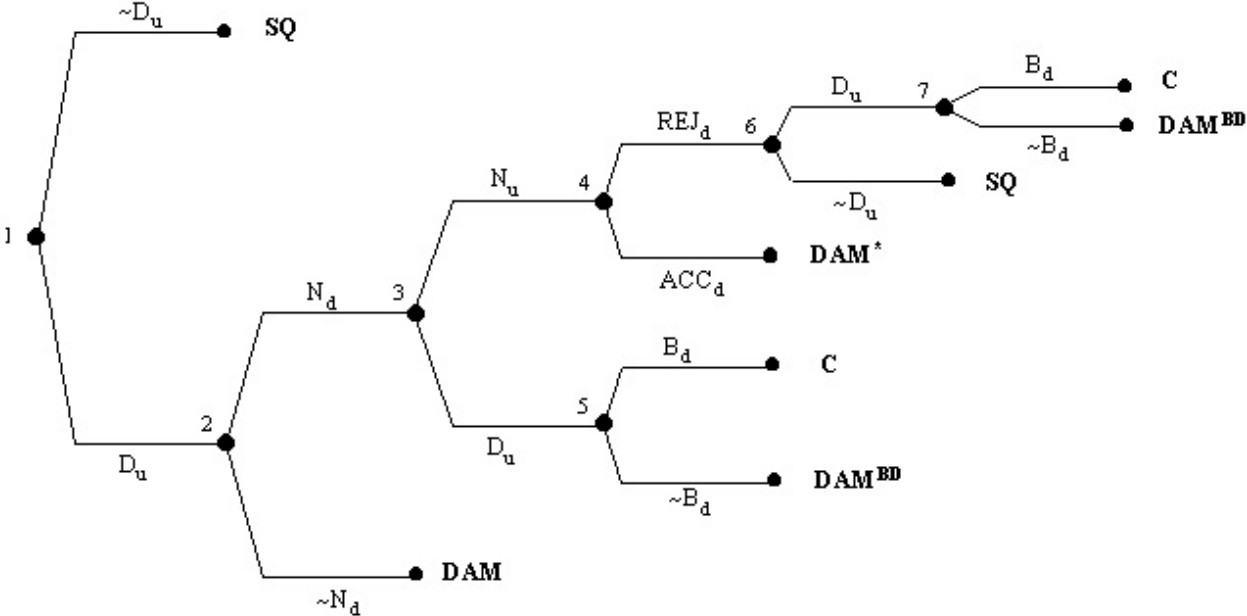

Figure 1 International Riparian Game

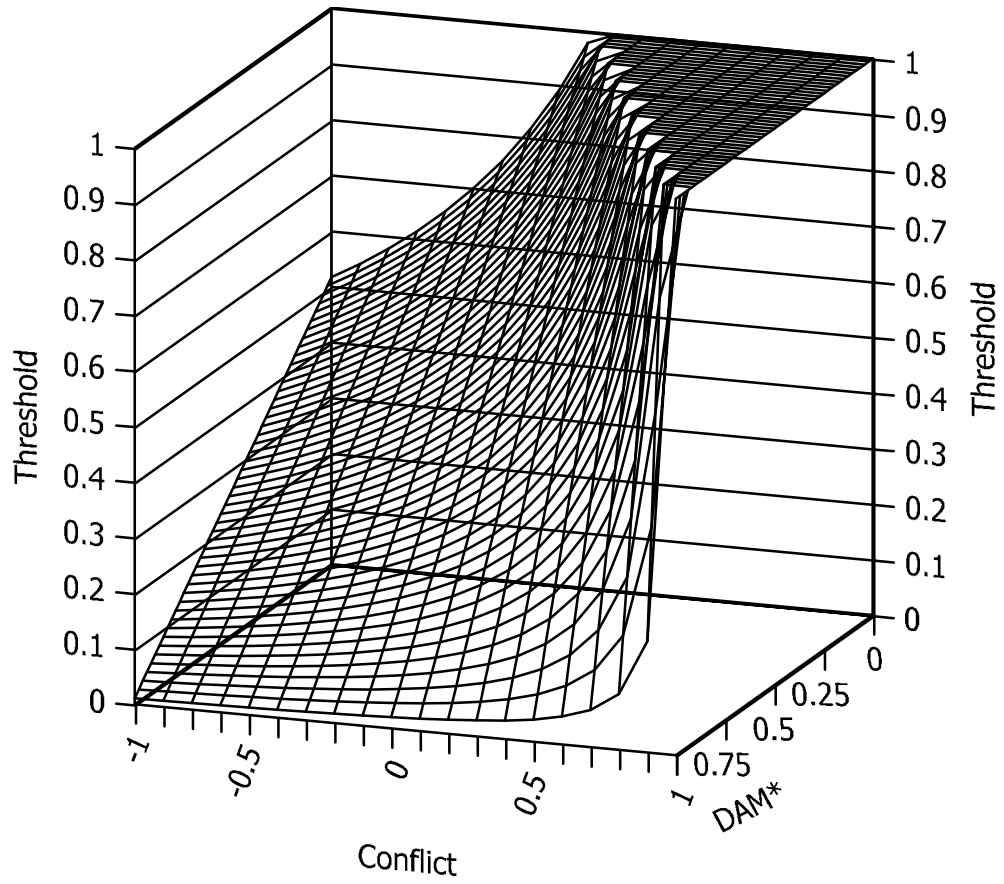

Figure 2 Critical threshold, $\bar{\lambda}_{crit}$, for upstream negotiators.

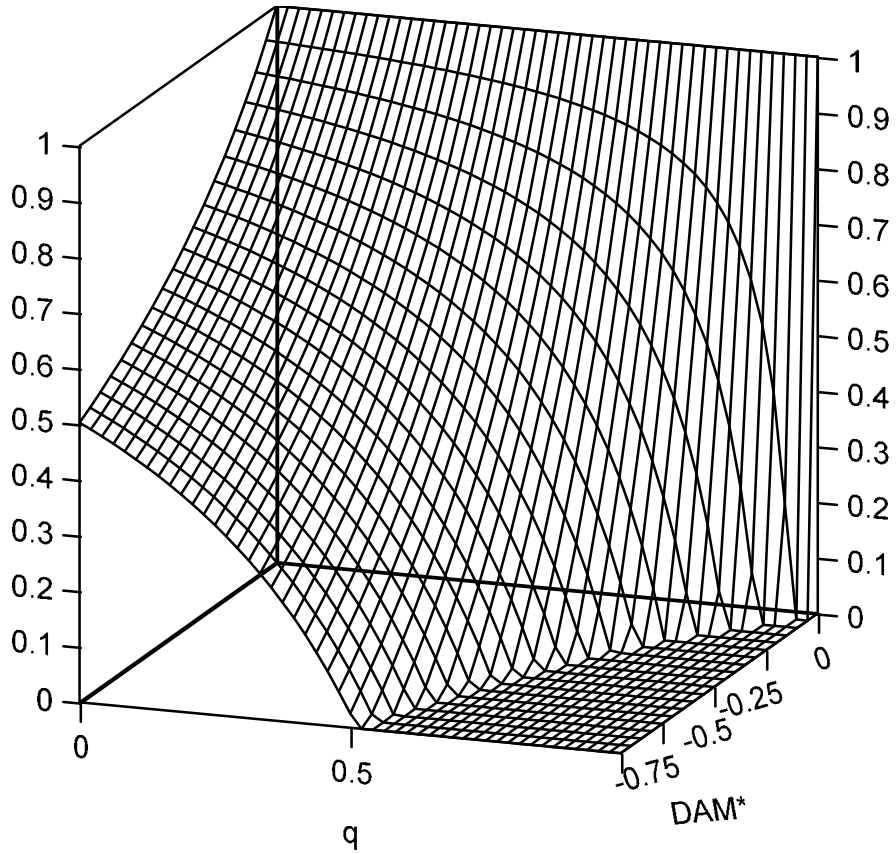

Figure 3 Additional threshold condition for upstream type u_2 (λ must be *below* the threshold in order for upstream to choose D_u at node 1)

Tables

	Upstream Types						Downstream Types			
	Relenters		Negotiators		Fighters		Strong		Weak	
Pref	u ₁	u ₂	u ₃	u ₄	u ₅	u ₆	d ₁	d ₂	d ₃	d ₄
best	DAM	DAM	DAM	DAM	DAM	DAM	DAM*	SQ	DAM*	SQ
▼	SQ	SQ	DAM*	DAM*	C	C	SQ	DAM*	SQ	DAM*
▼	C	DAM*	SQ	C	DAM*	SQ	C	C	DAM/DAM ^{BD}	DAM/DAM ^{BD}
worst	DAM*	C	C	SQ	SQ	DAM*	DAM/DAM ^{BD}	DAM/DAM ^{BD}	C	C

NOTE: Since we assume that upstream actors are indifferent between DAM and DAM^{BD}, we omit inclusion of DAM^{BD} in the preference rankings for upstream types.

Table 1 Upstream and Downstream Actor Preferences

APPENDIX

Each of the following are Bayesian perfect equilibria. To demonstrate the validity of these equilibria it is necessary to demonstrate that the strategies are best replies to each other given initial beliefs.

Equilibrium 1

PLAYERS: upstream type: u_4 ; downstream type: d_2 with probability λ and d_4 with probability $1-\lambda$

INITIAL BELIEFS: $\lambda < \bar{\lambda}_{crit} = \frac{1 - U_{u_4}(DAM^*)}{1 - U_{u_4}(C)}$

MOVES:

Node 1: D_u

Node 2 (d_2): N_d

Node 2 (d_4): N_d with probability $\frac{\lambda(U_{u_4}(DAM^*) - U_{u_4}(C))}{(1 - U_{u_4}(DAM^*))(1 - \lambda)}$ and $\sim N_d$ with probability

$$1 - \left[\frac{\lambda(U_{u_4}(DAM^*) - U_{u_4}(C))}{(1 - U_{u_4}(DAM^*))(1 - \lambda)} \right]$$

Node 3: D_u with probability $\frac{U_{d_4}(DAM^*)}{U_{d_4}(DAM^*) - U_{d_4}(DAM^{BD})}$; N_u with probability

$$1 - \frac{U_{d_4}(DAM^*)}{U_{d_4}(DAM^*) - U_{d_4}(DAM^{BD})}$$

Node 4 (d_2): ACC_d

Node 4 (d_4): ACC_d

Node 5 (d_2): B_d

Node 5 (d_4): $\sim B_d$

Node 6: D_u

Node 7 (d_2): B_d

Node 7 (d_4): $\sim B_d$

To demonstrate the validity of this equilibrium, we proceed by backwards induction. At node 7, since only d_2 prefers C over DAM^{BD} , it is only rational for d_2 to choose B_d . Downstream type d_4 chooses $\sim B_d$. The same logic applies to node 5. At node 6, u_4 's best reply is D_u regardless of its updated beliefs, $\bar{\lambda}$, because the possible outcomes to this choice (C and DAM^{BD}) are both preferred over the SQ . At node 4, ACC_d is a best reply for both downstream types because DAM^* is preferred to the anticipated outcome if either choose REJ_d .

Advancing to node 2, it can be seen that d_2 's best reply is N_u because possible outcomes from this choice are preferred to DAM . For d_4 , no pure strategy can be supported in a reasonable equilibrium. If d_4 chooses N_u all the time in equilibrium, u_4 will not be able to update its beliefs such that $\lambda = \bar{\lambda}$. Since $\lambda < \bar{\lambda}_{crit}$, u_4 will choose D_u at node 3, leading to an eventual outcome of DAM^{BD} for d_4 . Since DAM^{BD} is less preferred than DAM , such a pure strategy is not supported in equilibrium. If d_4 chooses $\sim N_d$ all the time in equilibrium, u_4 updates its beliefs at node 3 such that $\bar{\lambda} = 1$. This equilibrium cannot be supported, however, because d_4 's move is not a best reply. It would do better by choosing differently from the move prescribed by the equilibrium. Since no pure strategy is supported in equilibrium for d_4 , a mixed strategy must be invoked. As explained in the text, when d_4 chooses N_d with probability q at node 1, this creates

updated beliefs for u_4 such that $\bar{\lambda} = \bar{\lambda}_{crit}$. This makes u_4 indifferent between choosing N_u and D_u at node 3, which induces it to play a mixed strategy where it chooses D_u with probability p (and N_u with probability $1-p$). Finally, since SQ is the least preferred outcome for u_4 , its best reply at node 1 is to choose D_u since all of the anticipated outcomes from that choice are more preferred. \square

Equilibrium 2

PLAYERS: upstream type: u_4 ; downstream type: d_2 with probability λ and d_4 with probability $1-\lambda$

INITIAL BELIEFS: $\lambda > \bar{\lambda}_{crit} = \frac{1 - U_u(DAM^*)}{1 - U_u(C)}$

MOVES:

- Node 1: D_u
- Node 2 (d_2): N_d
- Node 2 (d_4): N_d
- Node 3: N_u
- Node 4 (d_2): ACC_d
- Node 4 (d_4): ACC_d
- Node 5 (d_2): B_d
- Node 5 (d_4): $\sim B_d$
- Node 6: D_u
- Node 7 (d_2): B_d
- Node 7 (d_4): $\sim B_d$

From node 4 onward, the logic supporting the moves in this equilibrium are the same as in equilibrium 1. At node 3, u_4 cannot update its beliefs about the downstream country since both downstream types make the same move at node 2. Since $\lambda > \bar{\lambda}_{crit}$, u_4 's best reply at node 3 is N_u . As in equilibrium 1, d_2 's best reply at node 2 is N_d . For d_4 , its best reply is to always choose N_d , leaving u_4 's beliefs unchanged at node 3. The anticipated result is an outcome of DAM^* , which d_4 prefers to DAM . As in equilibrium 1, u_4 's best reply at node 1 is D_u . \square

Equilibrium 3

PLAYERS: upstream type: u_3 ; downstream type: d_2 with probability λ and d_4 with probability $1-\lambda$

INITIAL BELIEFS: $\lambda > \bar{\lambda}_{crit} > \bar{\lambda}_{crit}$

MOVES:

- Node 1: D_u
- Node 2 (d_2): N_d
- Node 2 (d_4): N_d
- Node 3: N_u
- Node 4 (d_2): REJ_d
- Node 4 (d_4): REJ_d
- Node 5 (d_2): B_d
- Node 5 (d_4): $\sim B_d$

Node 6: $\sim D_u$
Node 7 (d₂): B_d
Node 7 (d₄): $\sim B_d$

The logic for the moves at nodes 5 and 7 is the same as in the above equilibria. At node 6, u_3 is indifferent between choosing D_u and $\sim D_u$ whenever the expected value of choosing D_u is equivalent to the value of the status quo, or when

$$U_u(SQ) = \bar{\lambda}(U_u(C)) + (1 - \bar{\lambda})(U_u(DAM^{BD}))$$

which reduces to

$$\bar{\lambda}_{crit} = \frac{1}{1 - U_u(C)}$$

In this equilibrium, $\bar{\lambda} = \lambda$ because both downstream types make the same moves throughout the game. Since $\lambda > \bar{\lambda}_{crit}$ in this equilibrium, u_3 's best reply at node 6 is $\sim D_u$. Since u_4 is anticipated to choose $\sim D_u$ at node 6 and since both downstream types prefer SQ over DAM^* , the best reply for d_2 and d_4 is REJ_d . Since $\bar{\lambda}_{crit} > \bar{\lambda}_{crit}$ for all upstream types, and since $\lambda > \bar{\lambda}_{crit}$ in this equilibrium, it must be the case that $\lambda > \bar{\lambda}_{crit}$.

Accordingly, equilibrium behavior at nodes 2 and 3 follows the logic described in Equilibrium 2 above. That is, both downstream types choose N_d at node 2 and u_4 chooses N_u at node 3. At node 1, u_3 is indifferent between accepting the SQ at node 1 or initiating the game with D_u and eventually accepting the SQ at node 6. □

Equilibrium 4

PLAYERS: upstream type: u_1 ; downstream type: d_2 with probability λ and d_4 with probability $1 - \lambda$

INITIAL BELIEFS: $\lambda < \frac{1}{1 - U_u(C)}$, where λ is the probability that downstream's type is d_2

Node 1: D_u
Node 2 (d₂): N_d
Node 2 (d₄): $\sim N_d$
Node 3: D_u
Node 4 (d₂): ACC_d
Node 4 (d₄): ACC_d
Node 5 (d₂): B_d
Node 5 (d₄): $\sim B_d$
Node 6: D_u
Node 7 (d₂): B_d
Node 7 (d₄): $\sim B_d$

The logic for the moves at nodes 5 and 7 is the same as in the above equilibria. Starting at node 6 and proceeding by backwards induction, it can be seen that this stage of the game is off the equilibrium path. We invoke the passive conjectures assumption about out-of-equilibrium beliefs (Rasmusen 1989, p. 114) and assume that the probability of d_2 choosing REJ_d at node 4 is equal to initial prior beliefs λ . Since

$\lambda < \frac{1}{1 - U_u(C)} = \bar{\lambda}_{crit}$, u_1 can be expected to choose D_u at node 6. Given the passive conjectures

assumption, ACC_d is a best reply for both d_2 and d_4 . At node 3, u_1 's best reply is D_u because both possible outcomes from that choice (C and DAM^{BD}) are preferred to DAM^* . At node 2, d_2 's best reply is N_d because the anticipated outcome, C, is preferred to DAM. For d_4 , however, $\sim N_d$ is the best reply because the anticipated outcome from demanding negotiations is DAM^{BD} and this outcome is less preferred than DAM.

At node 1, u_1 's best reply is D_u given that $\lambda < \frac{1}{1 - U_u(C)}$. □

Equilibrium 5

PLAYERS: upstream type: u_2 ; **downstream type:** d_2 with probability λ and d_4 with probability $1 - \lambda$

INITIAL BELIEFS: $\lambda < \bar{\lambda}_{crit} < \bar{\lambda}_{crit}$ and $\frac{q(U_u(DAM^*) - 1) + 1}{q(U_u(DAM^*) - 1) + 1 - DAM^*} > \lambda$

MOVES:

Node 1: D_u

Node 2 (d_2): N_d

Node 2 (d_4): N_d with probability $\frac{\lambda(U_u(DAM^*) - U_u(C))}{(1 - U_u(DAM^*))(1 - \lambda)}$ and $\sim N_d$ with probability

$$1 - \left[\frac{\lambda(U_u(DAM^*) - U_u(C))}{(1 - U_u(DAM^*))(1 - \lambda)} \right]$$

Node 3: D_u with probability $\frac{U_{d_4}(DAM^*)}{U_{d_4}(DAM^*) - U_{d_4}(DAM^{BD})}$; N_u with probability

$$1 - \frac{U_{d_4}(DAM^*)}{U_{d_4}(DAM^*) - U_{d_4}(DAM^{BD})}$$

Node 4 (d_2): ACC_d

Node 4 (d_4): ACC_d

Node 5 (d_2): B_d

Node 5 (d_4): $\sim B_d$

Node 6: D_u

Node 7 (d_2): B_d

Node 7 (d_4): $\sim B_d$

The logic for the moves at nodes 5 and 7 is the same as in the above equilibria. In this equilibrium, node 6 is off the equilibrium path. We invoke the passive conjectures assumption that $\lambda < \bar{\lambda}_{crit}$. Consequently, u_2 's best reply at node 6 is D_u . Given u_2 's anticipated behavior at node 6, the best reply for both downstream types at node 4 is ACC_d . At nodes 2 and 3 equilibrium strategies are similar to those in Equilibrium 1 since $\lambda < \bar{\lambda}_{crit}$. Upstream and downstream types invoke the same mixed strategies as in Equilibrium 1. At node 1, the expected value of choosing D_u can be expressed as

$$EV_{u_2}(D_{u_2}) = \lambda(U_{u_2}(DAM^*)) + (1 - \lambda)[q(U_{u_2}(DAM^*)) + 1 - q]$$

It can be shown that the expected value of choosing D_u is greater than the value of the status quo whenever the following expression is true.

$$\frac{q(U_u(DAM^*) - 1) + 1}{q(U_u(DAM^*) - 1) + 1 - DAM^*} > \lambda$$

Since this is a stated condition for this equilibrium, D_u is a best reply at node 1. □